

# DATA SHEET

**TDA8575**

**Ground noise isolation amplifier**

Preliminary specification  
File under Integrated Circuits, IC01

1996 Jul 29

## Ground noise isolation amplifier

## TDA8575

## FEATURES

- High common mode rejection up to high frequencies
- Reduced dependency of common mode rejection on source resistance
- Low distortion
- Low noise
- AC and DC short-circuit safe
- Few external components
- ESD protected on all pins.

## GENERAL DESCRIPTION

The TDA8575(T) is a two channel amplifier with differential input and single-ended output for use in car audio applications. The differential amplifier has a gain of 0 dB, a low distortion and a high common mode rejection. The TDA8575T comes in a 16 pin SO package and TDA8575 comes in a 16 pin DIP package.

The TDA8575(T) is developed for those car audio applications where long connections between signal sources and amplifiers (or boosters) are necessary and ground noise has to be eliminated.

## QUICK REFERENCE DATA

SYMBOL	PARAMETER	CONDITIONS	MIN.	TYP.	MAX.	UNIT
$V_{CC}$	supply voltage		5	8.5	18	V
$I_{CC}$	supply current	$V_{CC} = 8.5\text{ V}$	–	12.6	15	mA
$G_v$	voltage gain		–0.5	0	+0.5	dB
$V_{o(rms)(max)}$	maximum output voltage (RMS value)	THD = 0.1%	–	1.7	–	V
SVRR	supply voltage ripple rejection		55	60	–	dB
CMRR	common mode rejection ratio	$R_s = 0\ \Omega$	–	80	–	dB
THD	total harmonic distortion	$V_{o(rms)} = 1\text{ V}; f = 1\text{ kHz}$	–	0.005	–	%
$V_{no}$	noise output voltage		–	3.7	5	$\mu\text{V}$
$ Z_i $	input impedance		–	108	–	$\text{k}\Omega$
$ Z_o $	output impedance		–	–	10	$\Omega$

## ORDERING INFORMATION

TYPE NUMBER	PACKAGE		
	NAME	DESCRIPTION	VERSION
TDA8575T	SO16	plastic small outline package; 16 leads; body width 3.9 mm	SOT109-1
TDA8575	DIP16	plastic dual in-line package; 16 leads (300 mil); long body	SOT38-1

Ground noise isolation amplifier

TDA8575

BLOCK DIAGRAM

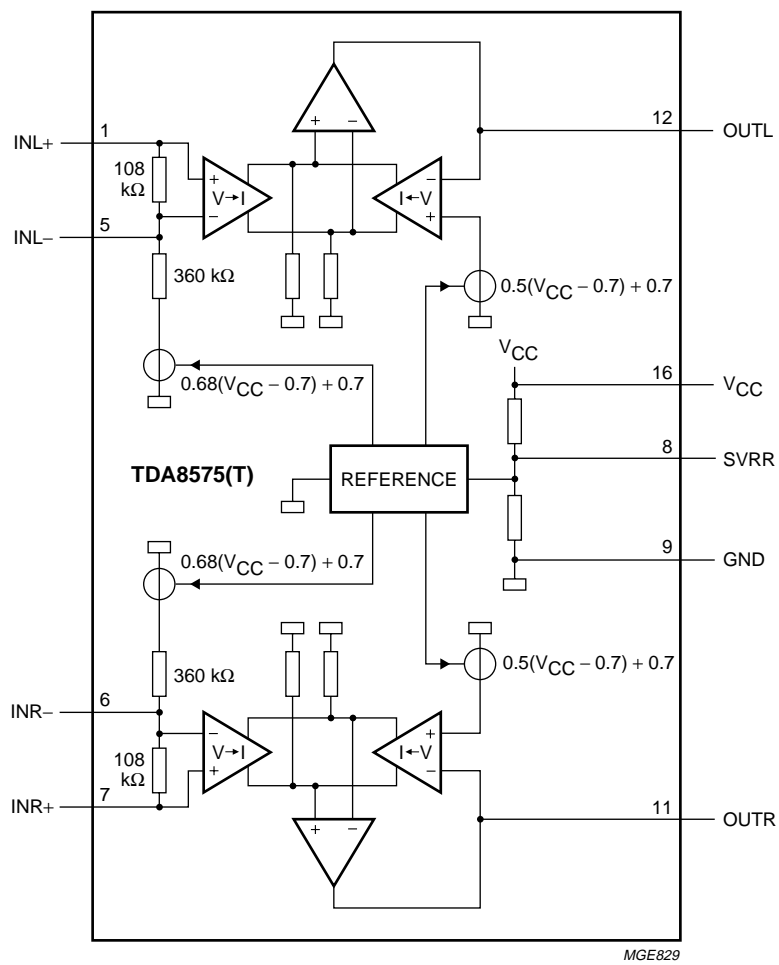

Fig.1 Block diagram.

Ground noise isolation amplifier

TDA8575

PINNING

SYMBOL	PIN	DESCRIPTION
INL+	1	positive input left
n.c.	2	not connected
n.c.	3	not connected
n.c.	4	not connected
INL-	5	negative input left
INR-	6	negative input right
INR+	7	positive input right
SVRR	8	supply voltage ripple rejection
GND	9	ground
n.c.	10	not connected
OUTR	11	output voltage right channel
OUTL	12	output voltage left channel
n.c.	13	not connected
n.c.	14	not connected
n.c.	15	not connected
V <sub>CC</sub>	16	supply voltage

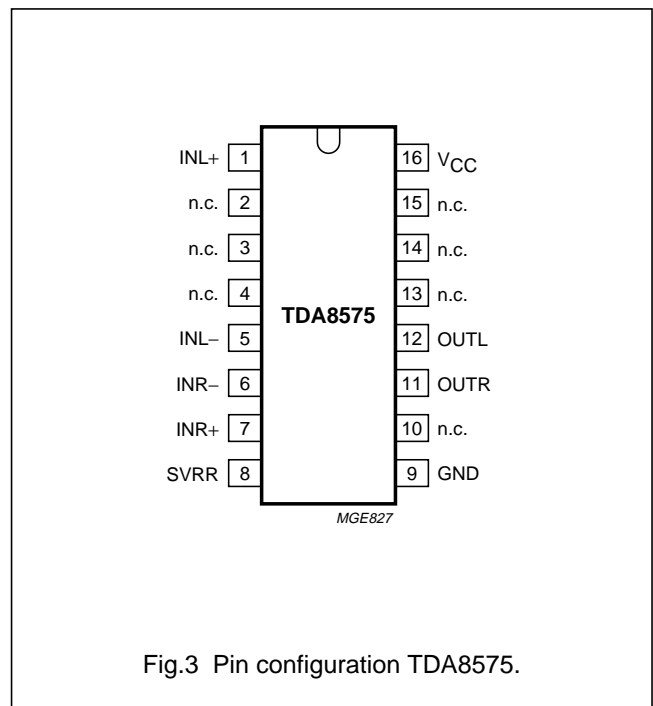
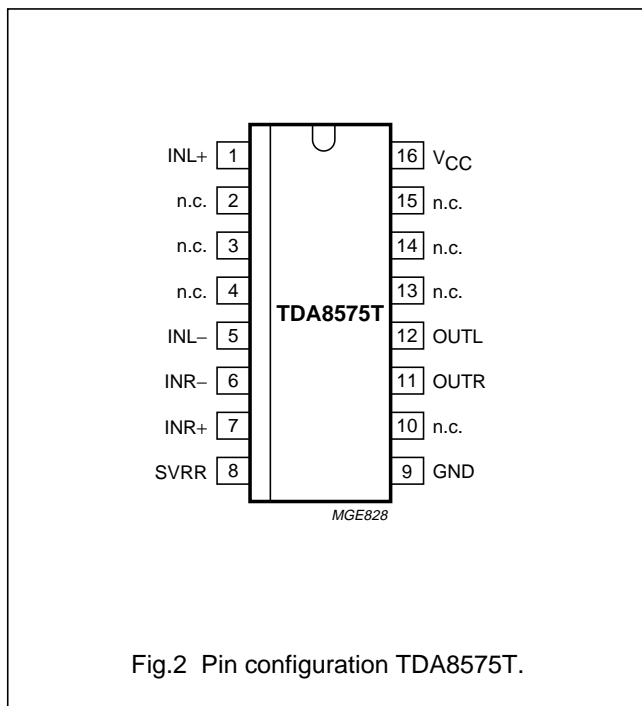

# Ground noise isolation amplifier

# TDA8575

## FUNCTIONAL DESCRIPTION

### System description

To enable a high common mode rejection a new system setup is used. The voltage to current converter, referred to as  $V \rightarrow I$  in the block diagram of Fig.1, replaces the resistors that can be seen in the conventional system solution.

Both systems are shown in Figs 4 and 5. In the conventional system the common mode rejection is limited by the matching properties of the resistors resulting in a CMRR of 60 dB maximum. Using the new system setup a CMRR of 80 dB is achieved.

### Power on

In Fig.6 the preferred input capacitor values are shown. If the capacitor  $C2 = 22 \mu F$  connected to the IN- inputs had to be charged by the  $0.5V_{CC}$  voltage source a charge time of  $5\tau = 5 \times \frac{360 \text{ k}\Omega}{2} \times 22 \mu F = 20 \text{ s}$  would be required.

This is inconvenient for most applications and therefore the TDA8575(T) is equipped with a quick charge circuit. On power-on the quick charge circuit charges the capacitor C2 connected to the IN- pins. The quick charge circuit consists of a voltage buffer and a control circuit (referred to as 'reference and power check' in Fig.6) that monitors the supply voltage  $V_{CC}$ . If the supply voltage rises more than  $\approx 2 \text{ V}$  the voltage buffer is switched on. After charging C2 the voltage buffer is switched off. The charge time of C2 will equal the charge time of C4, the SVRR capacitor.

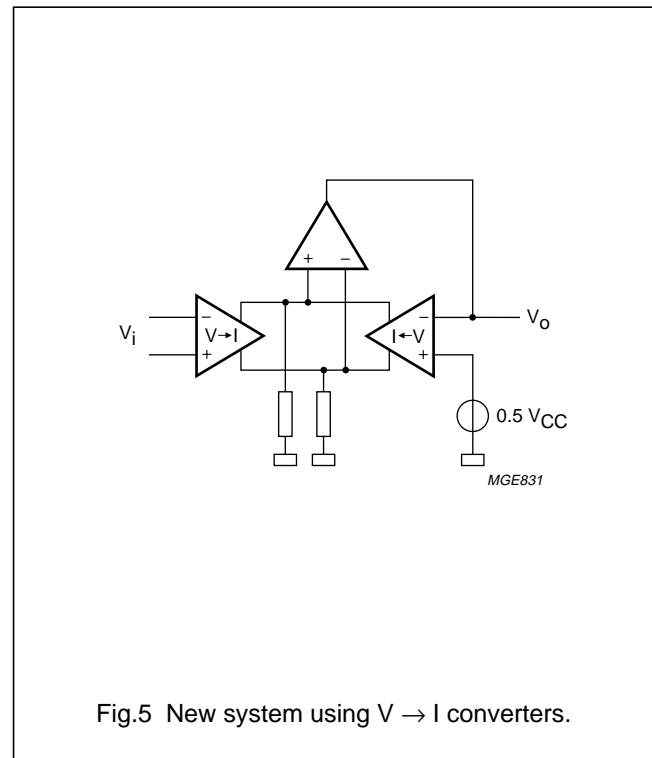
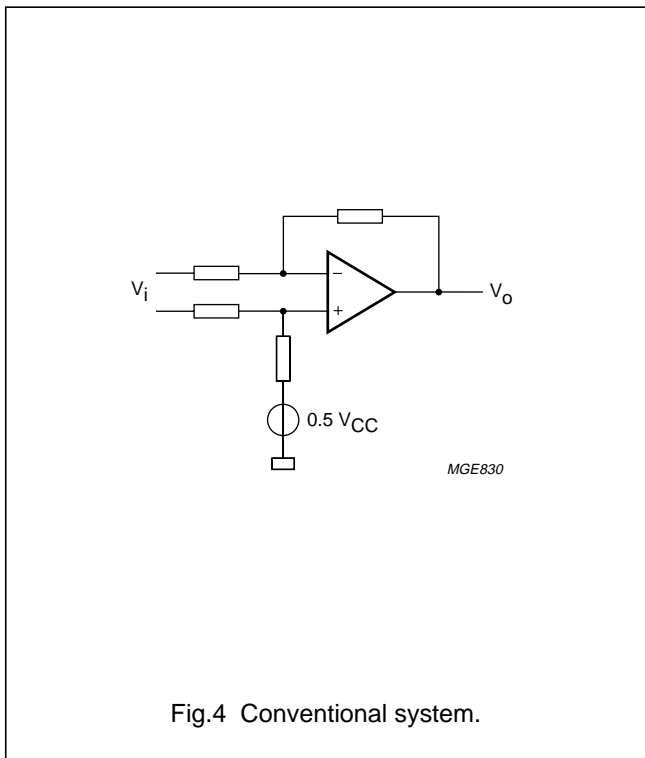

Ground noise isolation amplifier

TDA8575

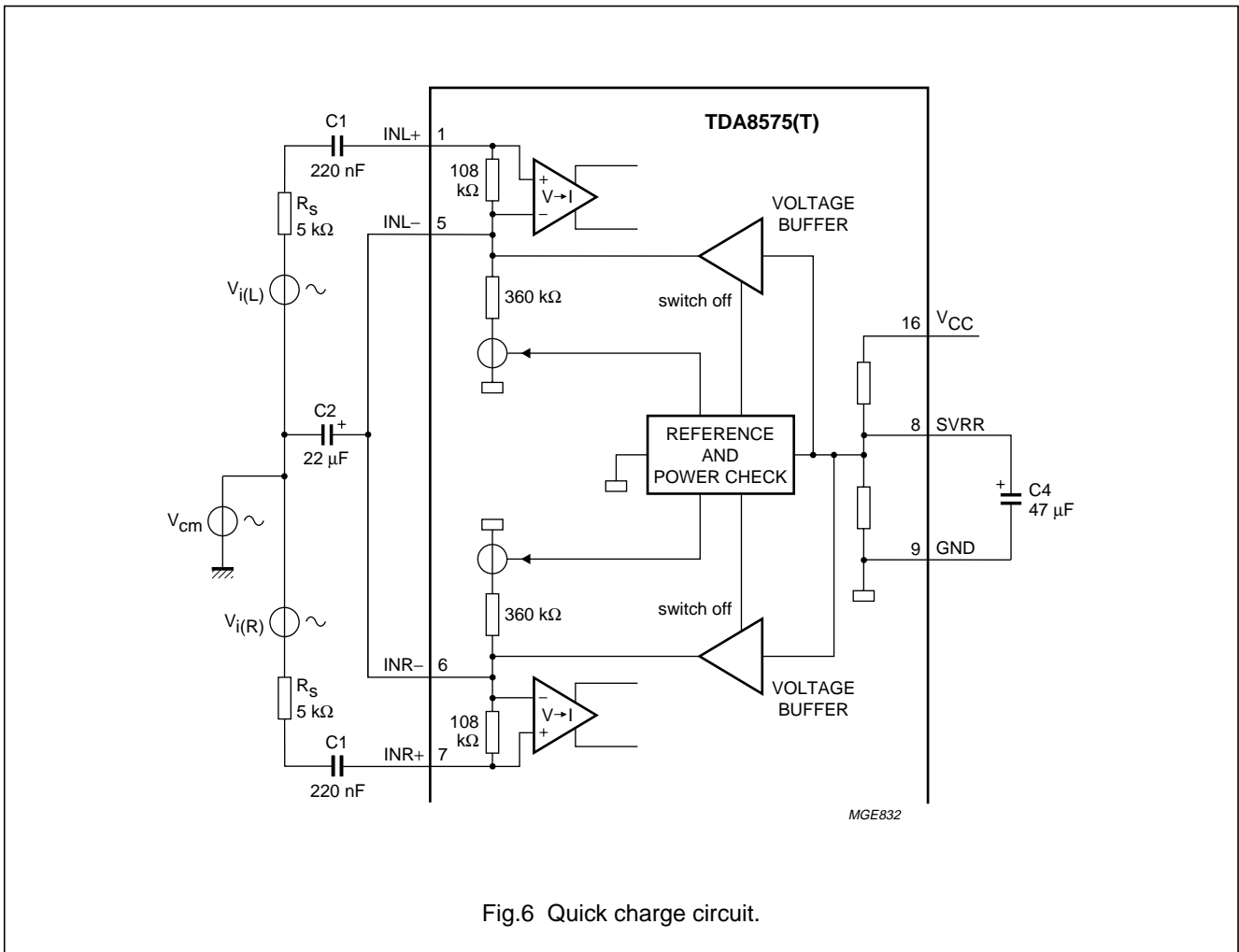

Fig.6 Quick charge circuit.

## Ground noise isolation amplifier

## TDA8575

**LIMITING VALUES**

In accordance with the Absolute Maximum Rating System (IEC 134).

SYMBOL	PARAMETER	CONDITIONS	MIN.	MAX.	UNIT
$V_{CC}$	supply voltage	operating	–	18	V
$I_{ORM}$	repetitive peak output current		–	40	mA
$V_{sc}$	AC and DC short-circuit safe voltage		–	18	V
$T_{stg}$	storage temperature		–55	+150	°C
$T_{amb}$	operating ambient temperature		–40	+85	°C
$T_j$	junction temperature		–	+150	°C

**THERMAL CHARACTERISTICS**

SYMBOL	PARAMETER	VALUE	UNIT
$R_{th\ j-a}$	thermal resistance from junction to ambient in free air		
	TDA8575 (DIP16)	75	K/W
	TDA8575T (SO16)	110	K/W

**QUALITY SPECIFICATION**

Quality according to *UZW-BO/FQ-0601*, if this type is used as an audio amplifier.

**DC CHARACTERISTICS**

$V_{CC} = 8.5\text{ V}$ ;  $T_{amb} = 25\text{ °C}$ ;  $R_L = 10\text{ k}\Omega$ ; in accordance with application circuit (see Fig.9).

SYMBOL	PARAMETER	CONDITIONS	MIN.	TYP.	MAX.	UNIT
$V_{CC}$	supply voltage	$V_i = 0\text{ V}$	5	8.5	18	V
$I_{CC}$	supply current		–	12.6	15	mA
$V_O$	output voltage	note 1	–	4.7	–	V

**Note**

1. The DC output voltage with respect to ground is approximately  $0.5V_{CC}$ .

## Ground noise isolation amplifier

TDA8575

**AC CHARACTERISTICS** $V_{CC} = 8.5 \text{ V}$ ;  $f = 1 \text{ kHz}$ ;  $R_S = 0 \text{ k}\Omega$ ;  $R_L = 10 \text{ k}\Omega$ ;  $T_{amb} = 25 \text{ }^\circ\text{C}$ ; in accordance with application circuit (see Fig.9).

SYMBOL	PARAMETER	CONDITIONS	MIN.	TYP.	MAX.	UNIT
$G_V$	voltage gain		-0.5	0	+0.5	dB
$\alpha_{cs}$	channel separation	$R_S = 5 \text{ k}\Omega$ ; note 1	70	80	-	dB
$ \Delta G_V $	channel unbalance		-	-	0.5	dB
$f_{ro(L)}$	low frequency roll-off	-1 dB; note 2	-	-	20	Hz
$f_{ro(H)}$	high frequency roll-off	-1 dB	20	-	-	kHz
$ Z_i $	input impedance		80	108	123	k $\Omega$
$ Z_o $	output impedance		-	-	10	$\Omega$
$V_{i(rms)(max)}$	maximum input voltage (RMS value)	THD = 1%	-	1.7	-	V
$V_{no}$	noise output voltage	unweighted; note 3	-	3.7	5	$\mu\text{V}$
THD	total harmonic distortion	$V_{i(rms)} = 1 \text{ V}$	-	0.005	0.01	%
		$V_{i(rms)} = 1 \text{ V}$ ; $f = 20 \text{ Hz to } 20 \text{ kHz}$	-	0.01	-	%
THD <sub>max</sub>	total harmonic distortion at maximum output current	$V_{i(rms)} = 1 \text{ V}$ ; $R_L = 150 \text{ }\Omega$	-	-	1	%
$V_{i(cm)(rms)}$	common-mode input voltage (RMS value)		-	-	1	V
CMRR	common-mode rejection ratio	$R_S = 5 \text{ k}\Omega$	66	80	-	dB
		$R_S = 0 \text{ }\Omega$ ; note 4 $f = 100 \text{ Hz to } 20 \text{ kHz}$	-	80	-	dB
SVRR	supply voltage ripple rejection	$R_S = 2 \text{ k}\Omega$ ; note 5	55	-	-	dB
		$R_S = 2 \text{ k}\Omega$ ; note 5 $f = 20 \text{ Hz to } 20 \text{ kHz}$	-	60	-	dB

**Notes**

1. The channel separation is dependent on the capacitor C2 connected to the IN- input. The channel separation for low frequencies (<1 kHz) can be increased by using a larger capacitance for C2.
2. The frequency response is externally fixed by the input and output coupling capacitors.
3. The noise output voltage is measured in a bandwidth of 20 Hz up to 20 kHz, unweighted.
4. The common mode rejection ratio is measured at the output with a voltage source  $V_{cm(rms)} = 1 \text{ V}$  and both  $V_{i(L)}$  and  $V_{i(R)}$  short-circuited according to Fig.9. The common mode rejection is dependent on the capacitor C2 connected to the IN- input. The common mode rejection for low frequencies (<1 kHz) can be increased by using a larger capacitance for C2.
5. Supply voltage ripple rejection is measured at the output using a ripple amplitude of 2 V (p-p). The source resistance  $R_S = 2 \text{ k}\Omega$ .



# Ground noise isolation amplifier

# TDA8575

## APPLICATION INFORMATION

### General

The TDA8575(T) is a two channel amplifier with differential input and single-ended output for use in car audio applications. The differential amplifier has a gain of 0 dB, a low distortion and a high common mode rejection.

Due to wiring resistance and noise coming from various electric devices in the automobile, performance loss will appear in those car audio applications where long connections between signal sources and amplifiers (or boosters) are necessary. To solve these problems the TDA8575(T) is developed (see Figs 7 and 8).

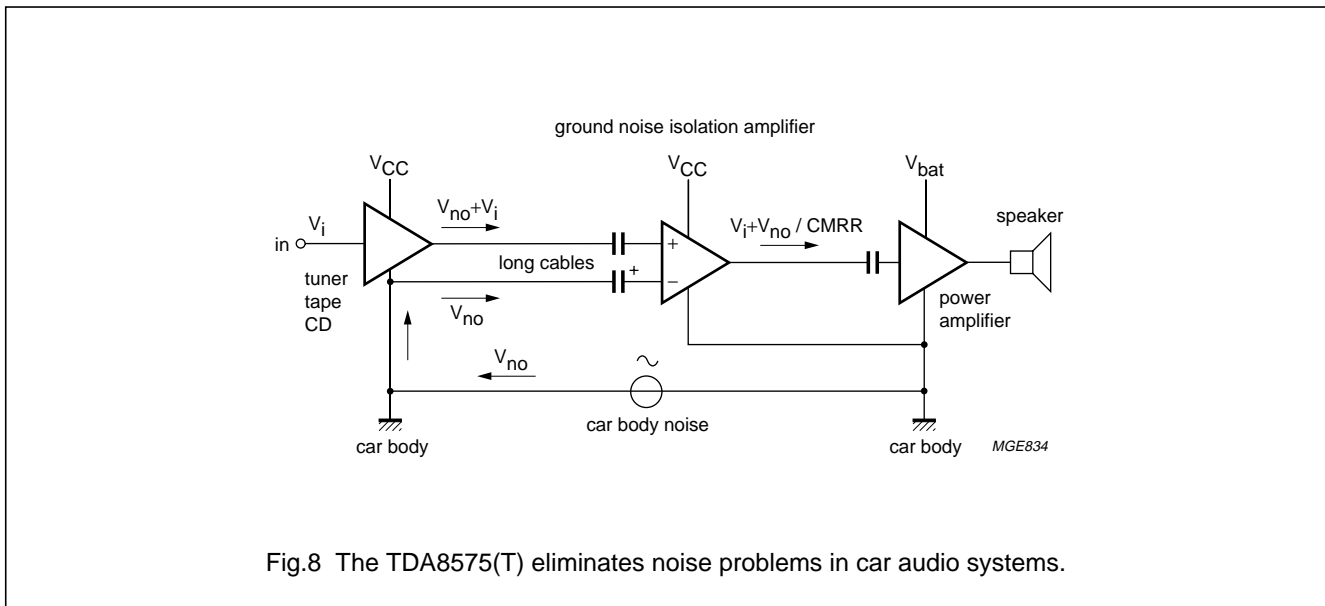
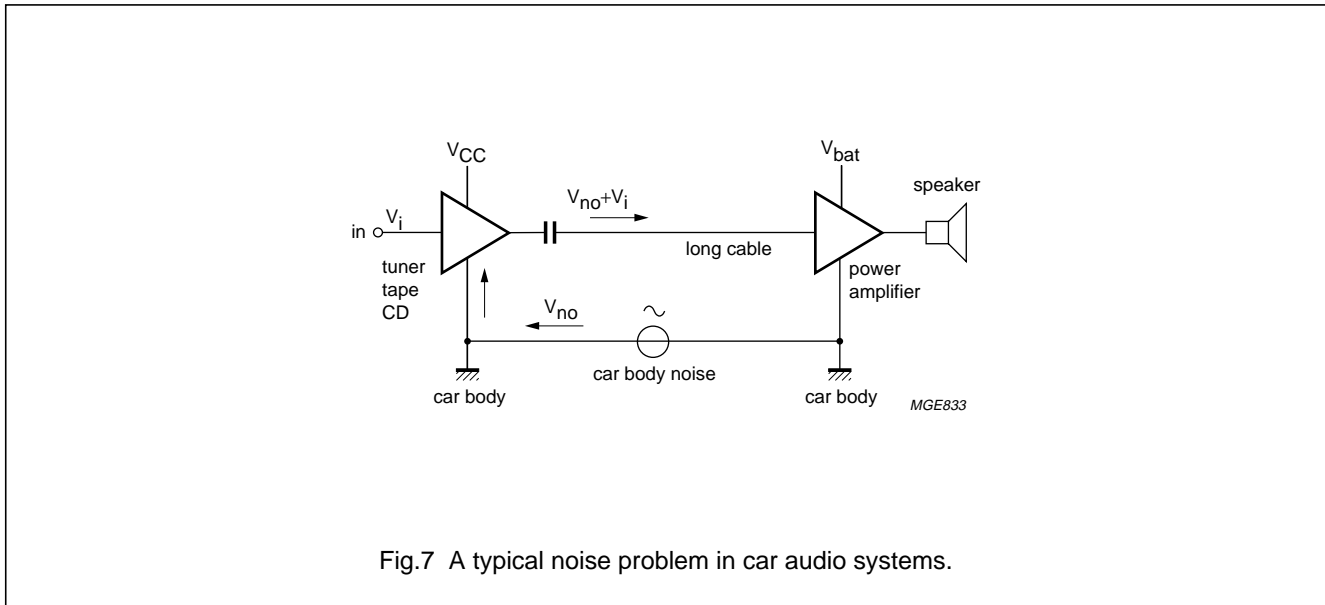

Ground noise isolation amplifier

TDA8575

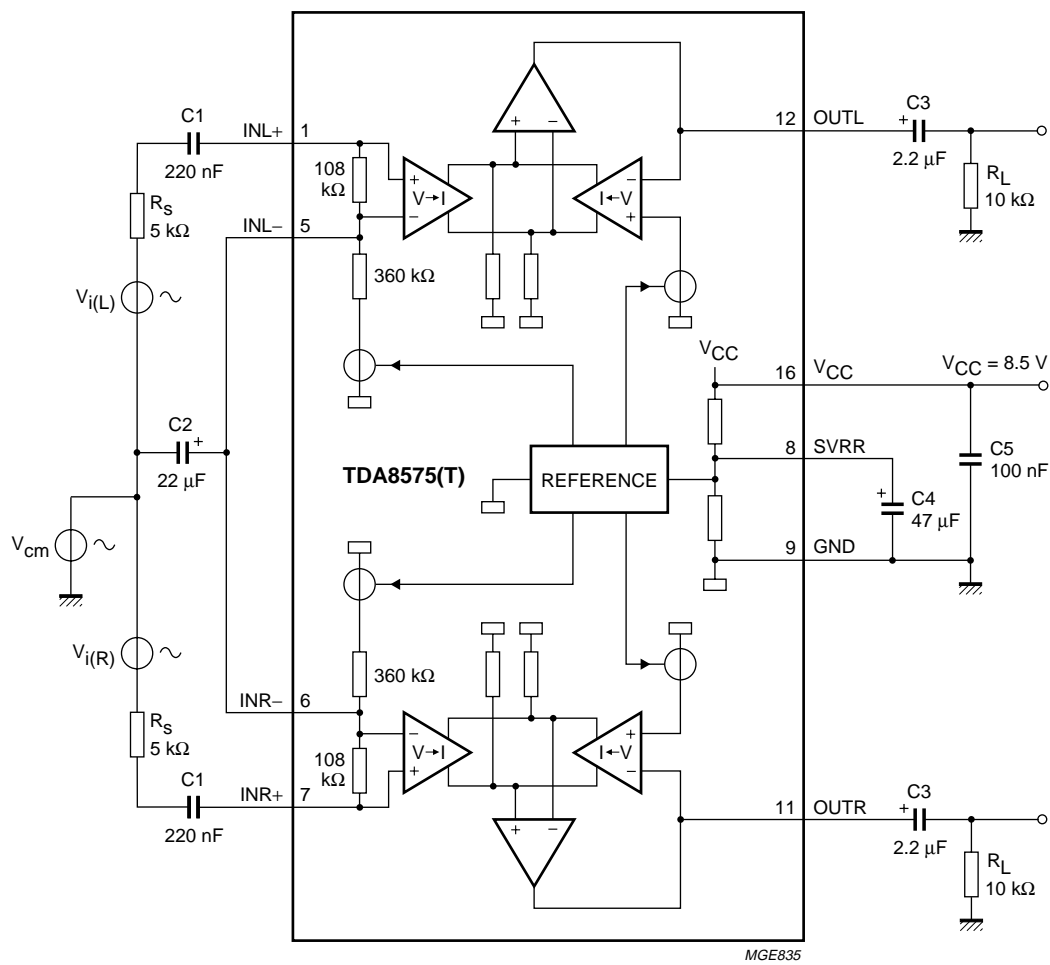

Fig.9 Application circuit TDA8575(T).

Ground noise isolation amplifier

TDA8575

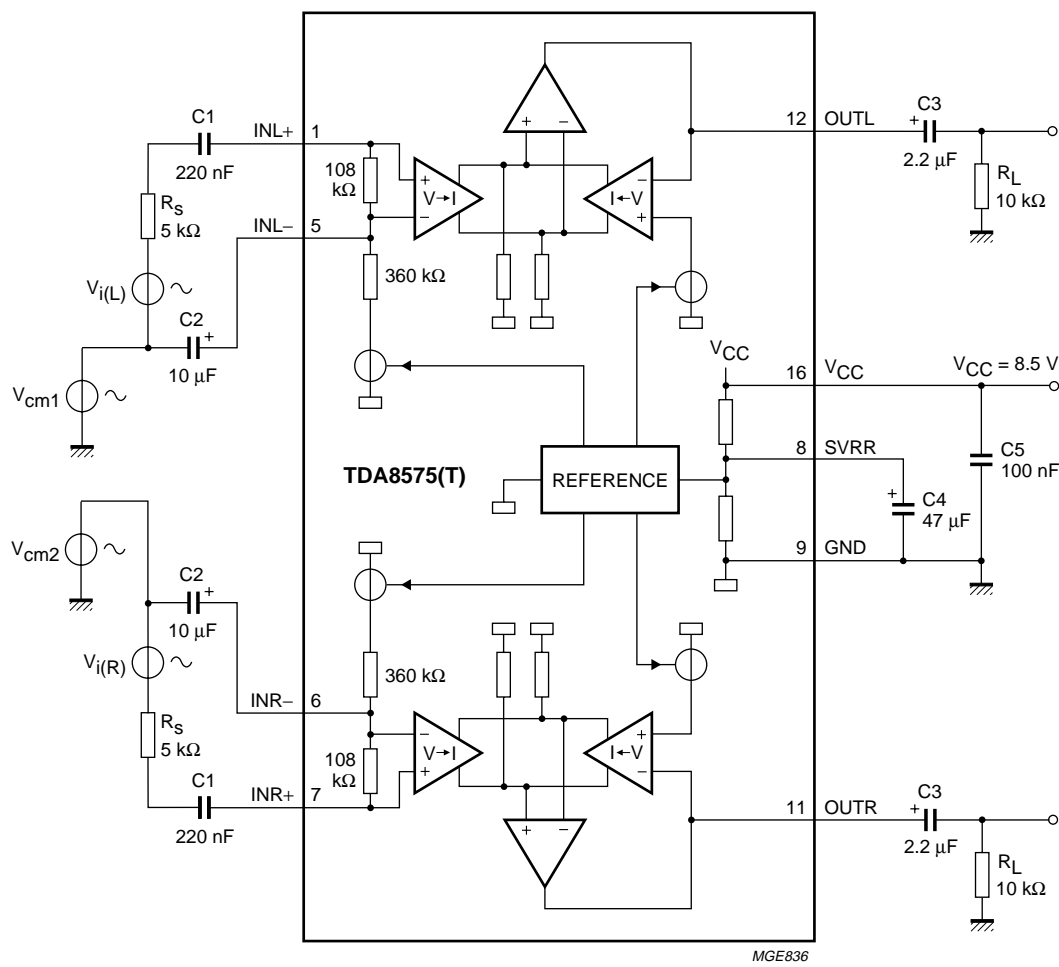

Fig.10 Application circuit TDA8575(T) with a balanced signal source.

Ground noise isolation amplifier

TDA8575

PACKAGE OUTLINES

SO16: plastic small outline package; 16 leads; body width 3.9 mm

SOT109-1

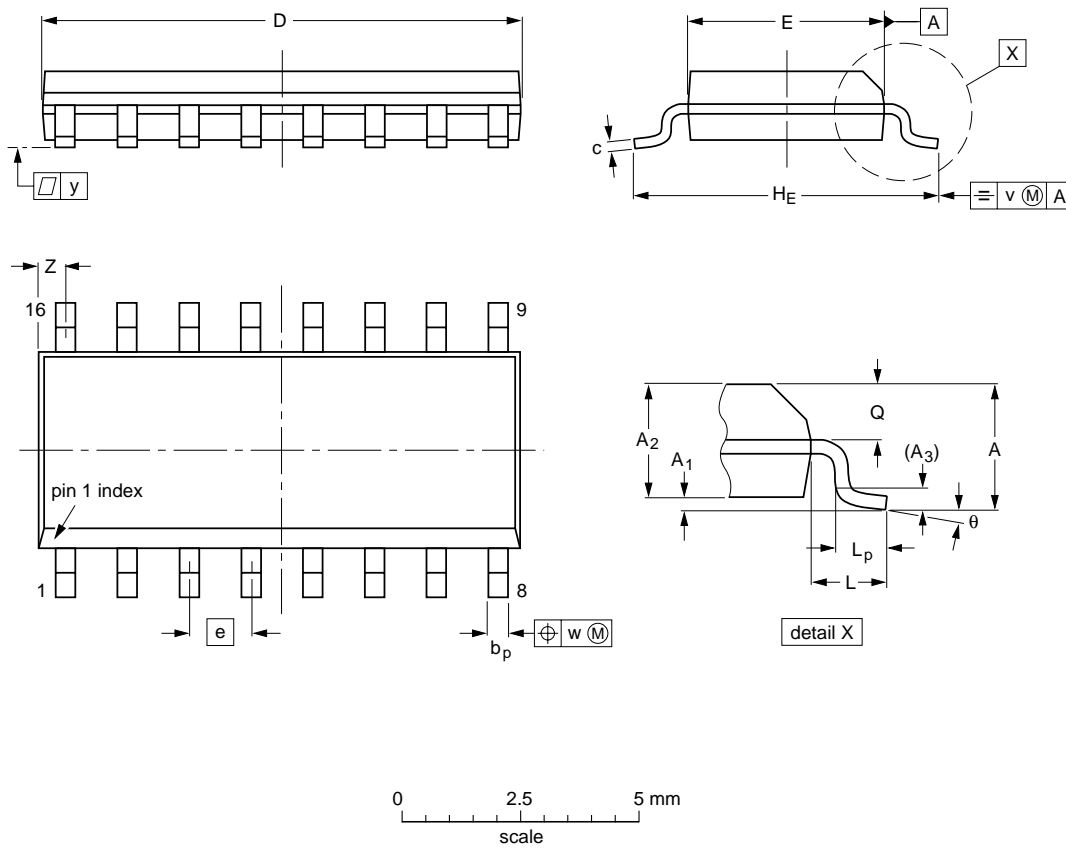

DIMENSIONS (inch dimensions are derived from the original mm dimensions)

UNIT	A max.	A <sub>1</sub>	A <sub>2</sub>	A <sub>3</sub>	b <sub>p</sub>	c	D <sup>(1)</sup>	E <sup>(1)</sup>	e	H <sub>E</sub>	L	L <sub>p</sub>	Q	v	w	y	Z <sup>(1)</sup>	θ
mm	1.75	0.25 0.10	1.45 1.25	0.25	0.49 0.36	0.25 0.19	10.0 9.8	4.0 3.8	1.27	6.2 5.8	1.05	1.0 0.4	0.7 0.6	0.25	0.25	0.1	0.7 0.3	8° 0°
inches	0.069	0.010 0.004	0.057 0.049	0.01	0.019 0.014	0.0100 0.0075	0.39 0.38	0.16 0.15	0.050	0.244 0.228	0.041	0.039 0.016	0.028 0.020	0.01	0.01	0.004	0.028 0.012	

Note

1. Plastic or metal protrusions of 0.15 mm maximum per side are not included.

OUTLINE VERSION	REFERENCES				EUROPEAN PROJECTION	ISSUE DATE
	IEC	JEDEC	EIAJ			
SOT109-1	076E07S	MS-012AC				95-01-23 97-05-22

Ground noise isolation amplifier

TDA8575

DIP16: plastic dual in-line package; 16 leads (300 mil); long body

SOT38-1

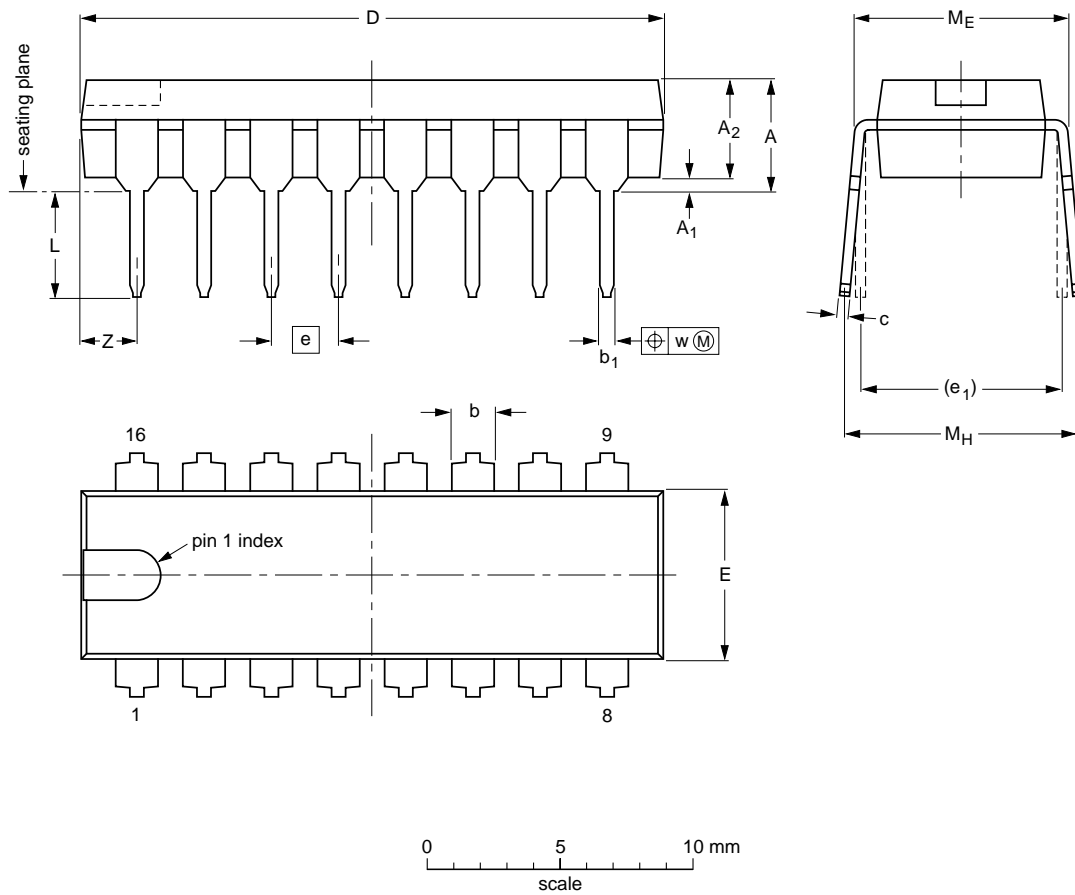

DIMENSIONS (inch dimensions are derived from the original mm dimensions)

UNIT	A max.	A <sub>1</sub> min.	A <sub>2</sub> max.	b	b <sub>1</sub>	c	D <sup>(1)</sup>	E <sup>(1)</sup>	e	e <sub>1</sub>	L	M <sub>E</sub>	M <sub>H</sub>	w	Z <sup>(1)</sup> max.
mm	4.7	0.51	3.7	1.40 1.14	0.53 0.38	0.32 0.23	21.8 21.4	6.48 6.20	2.54	7.62	3.9 3.4	8.25 7.80	9.5 8.3	0.254	2.2
inches	0.19	0.020	0.15	0.055 0.045	0.021 0.015	0.013 0.009	0.86 0.84	0.26 0.24	0.10	0.30	0.15 0.13	0.32 0.31	0.37 0.33	0.01	0.087

Note

1. Plastic or metal protrusions of 0.25 mm maximum per side are not included.

OUTLINE VERSION	REFERENCES				EUROPEAN PROJECTION	ISSUE DATE
	IEC	JEDEC	EIAJ			
SOT38-1	050G09	MO-001AE				92-10-02 95-01-19

## Ground noise isolation amplifier

TDA8575

### SOLDERING

#### Introduction

There is no soldering method that is ideal for all IC packages. Wave soldering is often preferred when through-hole and surface mounted components are mixed on one printed-circuit board. However, wave soldering is not always suitable for surface mounted ICs, or for printed-circuits with high population densities. In these situations reflow soldering is often used.

This text gives a very brief insight to a complex technology. A more in-depth account of soldering ICs can be found in our *"IC Package Databook"* (order code 9398 652 90011).

#### DIP

##### SOLDERING BY DIPPING OR BY WAVE

The maximum permissible temperature of the solder is 260 °C; solder at this temperature must not be in contact with the joint for more than 5 seconds. The total contact time of successive solder waves must not exceed 5 seconds.

The device may be mounted up to the seating plane, but the temperature of the plastic body must not exceed the specified maximum storage temperature ( $T_{stg\ max}$ ). If the printed-circuit board has been pre-heated, forced cooling may be necessary immediately after soldering to keep the temperature within the permissible limit.

##### REPAIRING SOLDERED JOINTS

Apply a low voltage soldering iron (less than 24 V) to the lead(s) of the package, below the seating plane or not more than 2 mm above it. If the temperature of the soldering iron bit is less than 300 °C it may remain in contact for up to 10 seconds. If the bit temperature is between 300 and 400 °C, contact may be up to 5 seconds.

#### SO

##### REFLOW SOLDERING

Reflow soldering techniques are suitable for all SO packages.

Reflow soldering requires solder paste (a suspension of fine solder particles, flux and binding agent) to be applied to the printed-circuit board by screen printing, stencilling or pressure-syringe dispensing before package placement.

Several techniques exist for reflowing; for example, thermal conduction by heated belt. Dwell times vary between 50 and 300 seconds depending on heating method. Typical reflow temperatures range from 215 to 250 °C.

Preheating is necessary to dry the paste and evaporate the binding agent. Preheating duration: 45 minutes at 45 °C.

##### WAVE SOLDERING

Wave soldering techniques can be used for all SO packages if the following conditions are observed:

- A double-wave (a turbulent wave with high upward pressure followed by a smooth laminar wave) soldering technique should be used.
- The longitudinal axis of the package footprint must be parallel to the solder flow.
- The package footprint must incorporate solder thieves at the downstream end.

During placement and before soldering, the package must be fixed with a droplet of adhesive. The adhesive can be applied by screen printing, pin transfer or syringe dispensing. The package can be soldered after the adhesive is cured.

Maximum permissible solder temperature is 260 °C, and maximum duration of package immersion in solder is 10 seconds, if cooled to less than 150 °C within 6 seconds. Typical dwell time is 4 seconds at 250 °C.

A mildly-activated flux will eliminate the need for removal of corrosive residues in most applications.

##### REPAIRING SOLDERED JOINTS

Fix the component by first soldering two diagonally-opposite end leads. Use only a low voltage soldering iron (less than 24 V) applied to the flat part of the lead. Contact time must be limited to 10 seconds at up to 300 °C. When using a dedicated tool, all other leads can be soldered in one operation within 2 to 5 seconds between 270 and 320 °C.

## Ground noise isolation amplifier

TDA8575

**DEFINITIONS**

<b>Data sheet status</b>	
Objective specification	This data sheet contains target or goal specifications for product development.
Preliminary specification	This data sheet contains preliminary data; supplementary data may be published later.
Product specification	This data sheet contains final product specifications.
<b>Limiting values</b>	
Limiting values given are in accordance with the Absolute Maximum Rating System (IEC 134). Stress above one or more of the limiting values may cause permanent damage to the device. These are stress ratings only and operation of the device at these or at any other conditions above those given in the Characteristics sections of the specification is not implied. Exposure to limiting values for extended periods may affect device reliability.	
<b>Application information</b>	
Where application information is given, it is advisory and does not form part of the specification.	

**LIFE SUPPORT APPLICATIONS**

These products are not designed for use in life support appliances, devices, or systems where malfunction of these products can reasonably be expected to result in personal injury. Philips customers using or selling these products for use in such applications do so at their own risk and agree to fully indemnify Philips for any damages resulting from such improper use or sale.

# Philips Semiconductors – a worldwide company

**Argentina:** see South America

**Australia:** 34 Waterloo Road, NORTH RYDE, NSW 2113, Tel. +61 2 9805 4455, Fax. +61 2 9805 4466

**Austria:** Computerstr. 6, A-1101 WIEN, P.O. Box 213, Tel. +43 1 60 101, Fax. +43 1 60 101 1210

**Belarus:** Hotel Minsk Business Center, Bld. 3, r. 1211, Volodarski Str. 6, 220050 MINSK, Tel. +375 172 200 733, Fax. +375 172 200 773

**Belgium:** see The Netherlands

**Brazil:** see South America

**Bulgaria:** Philips Bulgaria Ltd., Energoproject, 15th floor, 51 James Bourchier Blvd., 1407 SOFIA, Tel. +359 2 689 211, Fax. +359 2 689 102

**Canada:** PHILIPS SEMICONDUCTORS/COMPONENTS, Tel. +1 800 234 7381

**China/Hong Kong:** 501 Hong Kong Industrial Technology Centre, 72 Tat Chee Avenue, Kowloon Tong, HONG KONG, Tel. +852 2319 7888, Fax. +852 2319 7700

**Colombia:** see South America

**Czech Republic:** see Austria

**Denmark:** Prags Boulevard 80, PB 1919, DK-2300 COPENHAGEN S, Tel. +45 32 88 2636, Fax. +45 31 57 1949

**Finland:** Sinikalliontie 3, FIN-02630 ESPOO, Tel. +358 615 800, Fax. +358 615 80920

**France:** 4 Rue du Port-aux-Vins, BP317, 92156 SURESNES Cedex, Tel. +33 1 40 99 6161, Fax. +33 1 40 99 6427

**Germany:** Hammerbrookstraße 69, D-20097 HAMBURG, Tel. +49 40 23 53 60, Fax. +49 40 23 536 300

**Greece:** No. 15, 25th March Street, GR 17778 TAVROS, Tel. +30 1 4894 339/911, Fax. +30 1 4814 240

**Hungary:** see Austria

**India:** Philips INDIA Ltd, Shivsagar Estate, A Block, Dr. Annie Besant Rd. Worli, MUMBAI 400 018, Tel. +91 22 4938 541, Fax. +91 22 4938 722

**Indonesia:** see Singapore

**Ireland:** Newstead, Clonskeagh, DUBLIN 14, Tel. +353 1 7640 000, Fax. +353 1 7640 200

**Israel:** RAPAC Electronics, 7 Kehilat Saloniki St, TEL AVIV 61180, Tel. +972 3 645 0444, Fax. +972 3 649 1007

**Italy:** PHILIPS SEMICONDUCTORS, Piazza IV Novembre 3, 20124 MILANO, Tel. +39 2 6752 2531, Fax. +39 2 6752 2557

**Japan:** Philips Bldg 13-37, Kohnan 2-chome, Minato-ku, TOKYO 108, Tel. +81 3 3740 5130, Fax. +81 3 3740 5077

**Korea:** Philips House, 260-199 Itaewon-dong, Yongsan-ku, SEOUL, Tel. +82 2 709 1412, Fax. +82 2 709 1415

**Malaysia:** No. 76 Jalan Universiti, 46200 PETALING JAYA, SELANGOR, Tel. +60 3 750 5214, Fax. +60 3 757 4880

**Mexico:** 5900 Gateway East, Suite 200, EL PASO, TEXAS 79905, Tel. +9-5 800 234 7381

**Middle East:** see Italy

**Netherlands:** Postbus 90050, 5600 PB EINDHOVEN, Bldg. VB, Tel. +31 40 27 82785, Fax. +31 40 27 88399

**New Zealand:** 2 Wagener Place, C.P.O. Box 1041, AUCKLAND, Tel. +64 9 849 4160, Fax. +64 9 849 7811

**Norway:** Box 1, Manglerud 0612, OSLO, Tel. +47 22 74 8000, Fax. +47 22 74 8341

**Philippines:** Philips Semiconductors Philippines Inc., 106 Valero St. Salcedo Village, P.O. Box 2108 MCC, MAKATI, Metro MANILA, Tel. +63 2 816 6380, Fax. +63 2 817 3474

**Poland:** Ul. Lukiska 10, PL 04-123 WARSZAWA, Tel. +48 22 612 2831, Fax. +48 22 612 2327

**Portugal:** see Spain

**Romania:** see Italy

**Russia:** Philips Russia, Ul. Usatcheva 35A, 119048 MOSCOW, Tel. +7 095 926 5361, Fax. +7 095 564 8323

**Singapore:** Lorong 1, Toa Payoh, SINGAPORE 1231, Tel. +65 350 2538, Fax. +65 251 6500

**Slovakia:** see Austria

**Slovenia:** see Italy

**South Africa:** S.A. PHILIPS Pty Ltd., 195-215 Main Road Martindale, 2092 JOHANNESBURG, P.O. Box 7430 Johannesburg 2000, Tel. +27 11 470 5911, Fax. +27 11 470 5494

**South America:** Rua do Rocio 220, 5th floor, Suite 51, 04552-903 São Paulo, SÃO PAULO - SP, Brazil, Tel. +55 11 821 2333, Fax. +55 11 829 1849

**Spain:** Balmes 22, 08007 BARCELONA, Tel. +34 3 301 6312, Fax. +34 3 301 4107

**Sweden:** Kottbygatan 7, Akalla, S-16485 STOCKHOLM, Tel. +46 8 632 2000, Fax. +46 8 632 2745

**Switzerland:** Allmendstrasse 140, CH-8027 ZÜRICH, Tel. +41 1 488 2686, Fax. +41 1 481 7730

**Taiwan:** PHILIPS TAIWAN Ltd., 23-30F, 66, Chung Hsiao West Road, Sec. 1, P.O. Box 22978, TAIPEI 100, Tel. +886 2 382 4443, Fax. +886 2 382 4444

**Thailand:** PHILIPS ELECTRONICS (THAILAND) Ltd., 209/2 Sanpavuth-Bangna Road Prakanong, BANGKOK 10260, Tel. +66 2 745 4090, Fax. +66 2 398 0793

**Turkey:** Talatpasa Cad. No. 5, 80640 GÜLTEPE/ISTANBUL, Tel. +90 212 279 2770, Fax. +90 212 282 6707

**Ukraine:** PHILIPS UKRAINE, 4 Patrice Lumumba str., Building B, Floor 7, 252042 KIEV, Tel. +380 44 264 2776, Fax. +380 44 268 0461

**United Kingdom:** Philips Semiconductors Ltd., 276 Bath Road, Hayes, MIDDLESEX UB3 5BX, Tel. +44 181 730 5000, Fax. +44 181 754 8421

**United States:** 811 East Arques Avenue, SUNNYVALE, CA 94088-3409, Tel. +1 800 234 7381

**Uruguay:** see South America

**Vietnam:** see Singapore

**Yugoslavia:** PHILIPS, Trg N. Pasica 5/v, 11000 BEOGRAD, Tel. +381 11 825 344, Fax. +381 11 635 777

**For all other countries apply to:** Philips Semiconductors, Marketing & Sales Communications, Building BE-p, P.O. Box 218, 5600 MD EINDHOVEN, The Netherlands, Fax. +31 40 27 24825

**Internet:** <http://www.semiconductors.philips.com>

© Philips Electronics N.V. 1996

SCA51

All rights are reserved. Reproduction in whole or in part is prohibited without the prior written consent of the copyright owner.

The information presented in this document does not form part of any quotation or contract, is believed to be accurate and reliable and may be changed without notice. No liability will be accepted by the publisher for any consequence of its use. Publication thereof does not convey nor imply any license under patent- or other industrial or intellectual property rights.

Printed in The Netherlands

517021/10/01/pp16

Date of release: 1996 Jul 29

Document order number: 9397 750 00985

*Let's make things better.*

**Philips  
Semiconductors**



**PHILIPS**